

Official Newsletter Department of Mechanical Engineering

अविन्या= वृद्धि

Insight to innovative growth

Editor-in-chief

Dr. Vaibhav Jain

Editor

Ms. Surabhi Lata

Student Editors

Mayank Agarwal

Vasu Kumar

Sundaram

Maharaja Agrasen Institute of Technology



VISION

To be a global leader in Mechanical Engineering education, research & innovation with ethics and values.

MISSION

M1: To deliver industry-relevant and skill-oriented education in Mechanical Engineering, encompassing production, design, thermal, and emerging areas to address diverse global challenges.

M2: To foster ethical values with professional skills for the benefit of industry and society.

M3: To enhance the teaching-learning process through modern pedagogical tools.

M4: To promote research, innovation, and entrepreneurship using sustainable technologies and continuous learning.

M5: To strengthen engagement with alumni, industry, and other stakeholders for collaborative growth and capacity building.

PROGRAM OBJECTIVES

The objectives of the department of Mechanical Engineering are to produce graduates who will have:

PEO1: Employability, entrepreneurship, leadership skills, and the ability to pursue higher education for the enhancement of knowledge.

PEO2: Ability to lead through research and innovation in the field of Mechanical Engineering.

PEO3: Engineering competence with good communication skills, professionalism, moral values as well as foundation for lifelong learning.

PEO4: Technical capabilities pertinent to Mechanical and allied engineering and to provide innovative and sustainable solutions for industrial and societal problems.

What's Inside

- ✚ Word from the Head
- ✚ GGSIPU Result
- ✚ Placement
- ✚ About the Societies
- ✚ Industrial Training at Daikin India Plant
- ✚ Webinar on Role of AI in Robots and Drones
- ✚ Bharat Mobility Global Expo 2025
- ✚ Inter-College Cricket Tournament
- ✚ Innovation Project for the Indian Navy by Ankit Rai
- ✚ Six-Month QIP Certificate Program
- ✚ Award for Dr. Vaibhav Jain at the ASHRAE Conference
- ✚ Blood Donation Camp
- ✚ Team Jatayu at eBAJA 2025, Hyderabad
- ✚ One-Week National Level FDP on "Green Manufacturing"
- ✚ Industrial Training at Jindal SAW Ltd
- ✚ Online Industrial Interaction with Jindal SAW Ltd.
- ✚ Industrial Visit to Yaskawa
- ✚ Inaugural Event of ASME- MAIT Student Section
- ✚ Seminar on Story of Mechanical Engineer After MS in the USA
- ✚ Workshop Organized by Team Focus at Park Inn
- ✚ One-day workshop on Multiphysics Simulation with Ansys
- ✚ Workshop on Heat Load Estimation
- ✚ Industrial Visit to Shri Ram Pistons & Piston Rings Pvt. Ltd.
- ✚ Job Expo & Capacity Building Session on JobX
- ✚ Team Aerostars at Boeing National Aeromodelling Competition
- ✚ ASME Seminar on AM & Chandigarh Section Launch
- ✚ Paper Presentation at ICACME 25 Conference
- ✚ Industrial Visit to Haier India
- ✚ Convocation Ceremony 2025
- ✚ Farewell Celebration 2021-25
- ✚ Visit of The Fourth Valley Concierge Corporation Team
- ✚ Awareness Drive on Sustainable Refrigeration by ASHRAE
- ✚ Industrial Training at Daikin India Pvt. Ltd, Neemrana
- ✚ Industrial Visit to Relaxo by Academic Team
- ✚ Dr. Vaibhav Jain Appointed as BOG Member and Chair
- ✚ CSR Grant by EMS Ltd. for development of Off-Road Vehicle
- ✚ Research Paper Presentation at IEMPOWER 25 Conference
- ✚ Industrial Visit to Relaxo by Faculty Team
- ✚ Three Day Faculty Development Program
- ✚ Recognition with Rising Star Award in ASHRAE Challenge
- ✚ Interaction of MEGA group with Team Aerostar and SAE Club
- ✚ PhD Award for Dr. Surbhi Upadhyay

WORD FROM THE HEAD

Dear Readers of *Avinya-Vrddhim*,

Warm greetings to all members of the Mechanical Engineering family! It gives me immense joy to connect with you through this latest edition of our biannual newsletter, a platform that captures the vibrant energy, progress, and spirit of innovation that defines our department.

In a discipline as dynamic as mechanical engineering, it is essential that we remain informed, inspired, and interconnected. This publication acts as a vital link, keeping our students, faculty, alumni, and industry partners updated on the impactful initiatives and remarkable achievements that have taken place in recent months.

I am proud to see the relentless efforts and unwavering passion demonstrated by our community — from faculty members pushing the frontiers of research, to students excelling in academics and projects, to staff members who support and sustain our daily endeavors. Together, we are building a strong foundation for future breakthroughs.

This issue brings you a curated collection of inspiring stories, research breakthroughs, student accolades, and collaborative ventures with the industry. It is a true testament to the hard work, curiosity, and creativity that drives our department forward.

A sincere thank you to all the contributors and the editorial team for bringing this edition to life. Your dedication ensures that this newsletter remains not just a record of progress, but a source of inspiration and pride for all of us.

As we step ahead, I invite each of you to stay engaged, share your ideas, and be active participants in the journey ahead. Let us continue to grow together as a community committed to excellence, innovation, and meaningful impact.

With best wishes for continued success and progress,

Dr. Vaibhav Jain

Head

Department of Mechanical Engineering



Faculty Pursuing PhD

1. Ms. Surabhi Lata

Department
Intake:

60

GGSIPO RESULTS (2024-2025)

4th Year Students Result till 8th SEM (2024-2025)

S. No.	Enrollment No.	Student Name	Percentage
1	03414811121	Sharmishta Menon	87.02 %
2	01514811121	Shashank Joshi	86.02 %
3	00514808222	Ashish Raj	87.30 %
4	04214811121	Viral Pandey	85.82 %
5	00514811121	Ansh Gupta	86.25 %
6	00314811121	Dhruv Aggarwal	85.98 %
7	04914811121	Sachin Kumar Jha	82.53 %

3rd Year Students Result till 6th SEM (2024-2025)

S. No.	Enrollment No.	Student Name	Percentage
1	01714811122	Jayant Buddala	87.16 %
2	01414811122	Prabhat Shankar Dubey	84.32 %
3	00114811122	Mayank Jatley	84.58 %
4	00514811122	Gokul Chawla	84.04 %
5	01314811122	Md Taufique Umar	83.51 %
6	00214811122	Mayank Agarwal	81.16 %
7	01214811122	Keshav Nandan	82.02 %

2nd Year Students Result till 4th SEM (2024-2025)

S. No.	Enrollment No.	Student Name	Percentage
1	01114811123	Kush Negi	83.00 %
2	02114811123	Tanmay Mathur	80.93 %
3	35614811123	Garv Jindal	82.27 %
4	01214811123	Devansh Chawla	78.93 %
5	00714811123	Veer Pratap Singh	78.53 %
6	02814811123	Sundaram	78.72 %
7	35114811123	Arihant Jain	76.65 %

PLACEMENTS (2021-2025)

S. No.	Student Name	Enrollment No.	Name of the Employer
1	Prasoon Sengar	04514811121	Authbridge Trust
2	Ashish Raj	00514808222	Daikin Air conditioning India Pvt. Ltd.
3	Prashant Yadav	01014808222	Effisense Consulting
4	Ayush Thukral	00214811121	Infosys
5	Zeeshan Ahmad	00314808222	The BIM Engineers
6	Shubham Bhardwaj	01314811121	Corizo
7	Aman Kumar	01114808222	Integrative Design Solutions
8	Manish Kumar	04414811121	Pregrad
9	Anubhav	04614811121	ETA Engineering Ltd.
10	Kishan Chauhan	20114811121	Festiva
11	Vaibhav Goyal	35614811121	SKH Marelli Pvt. Ltd.
12	Pradeep Singh	50314811121	Oswal Energies Ltd.
13	Shivangi Gupta	03314811121	Vision India Services
14	Tanuj Gautam	02814811121	Winspark Innovations Learning Pvt
15	Rahul Kumar	04714811121	Polestar
16	Shashank Joshi	01514811121	Studiokon Ventures Pvt. Ltd.
17	Chakshanshu	00614808222	Talbro's Automotive Components Ltd.
18	Vishal Verma	00414808222	Aircon engineer's Private Limited
19	Md Kaunain	01214808222	Aircon engineer's Private Limited
20	Abhishek	03814811121	Aircon engineer's Private Limited
21	Anshul Kumar	00214808222	Workex (GoMechanic)
22	Ankit Rawat	02014811121	Workex (GoMechanic)
23	Nitesh	50114811121	Workex (GoMechanic)
24	Lakshya Aswal	02114811121	Larsen & Toubro Limited
25	Dhruv Sharma	02714811121	Larsen & Toubro Limited
26	Sharmishta Menon	03414811121	Larsen & Toubro Limited
27	Akash Yadav	00914808222	Truostar Air Systems
28	Varsha Bachchas	04814811121	Truostar Air Systems
29	Sachin Kumar Jha	04914811121	Truostar Air Systems

About the Societies

ASHRAE, Student Chapter MAIT

Membership Number: 8370536

The ASHRAE Student Chapter MAIT was started in Feb 2019. Since its inception the ASHRAE Student Chapter MAIT has witnessed exponential growth. The society was started with 15 members under the guidance of Dr. Vaibhav Jain and its strength has been gradually increasing. The students of this chapter have shown extreme compassion and exuberance in discharging all the tasks taken up by them with utmost dedication and hard work. The Chapter has grown to be stronger, compassionate, tech savvy and slated to give the better engineers of tomorrow. They are continued to indulge in new, green and sustainable technological research and generated more practical experience in our society and with that work smart towards developing new models in the field of HVAC&R. Even, the COVID-19 couldn't stop them from doing their best and making the best use of the time at home and keep on expanding the chapter and its activities. ASHRAE is a world-renowned organization and they only want to uphold that name by constantly trying hard to be better than before.

Dr. Vaibhav Jain

3D SPACE: Additive Manufacturing Society of MAIT

3D Space: Additive Manufacturing Society of MAIT, founded in 2019 by 20 visionary students, is dedicated to advancing the field of additive manufacturing. The society aims to transform ideas into tangible solutions, fostering innovation through hands-on experience with 3D printing technology. One of its key focuses is enhancing students' CAD skills, enabling them to design complex models and bring their ideas to life in 3D form. It emphasizes on mastering Design for Additive Manufacturing (DFAM), ensuring members understand the nuances of designing specifically for 3D printing. The society is also involved in designing and building fully functional 3D printers and producing engineering-grade components that improve product functionality. Beyond technical skills, 3D Space encourages collaboration and idea sharing, promoting interdisciplinary projects and offering 3D printing services to other societies. The society stays at the cutting edge of the industry by engaging in research, organizing conferences, and participating in competitions. With a commitment to pushing boundaries and advancing knowledge, 3D Space plays a pivotal role in the MAIT community, empowering students to innovate and excel in the rapidly growing field of additive manufacturing.

Ms. Surabhi Lata

Aerostars

Team Aerostars is a group of like-minded aviation enthusiasts (aerophiles) advancing aerial technology and specializing in unmanned aerial vehicles (UAVs) through collaborative innovation and rigorous research. Founded in 2021 under the Mechanical Department of MAIT, Team Aerostars serves as a platform for professionals, researchers, and enthusiasts to share knowledge, exchange ideas, and foster partnerships that drive the evolution of UAV applications across various industries. Since then, we have relentlessly pursued innovation and excellence, transforming our enthusiasm into expertise. Our successes in competitions such as SAE India ADDC, TechnoXian, BML Munjal etc are a testament to our expertise and dedication. We stand as a beacon for students, empowering them to transition from technology consumers to creators. With a focus on integrating engineering, technology, and sports, Aerostars nurtures the innovators of tomorrow. As we continue to expand and reach new heights, our motto, "In Thrust, We Trust," drives us forward.

Dr. Kanchan Mudgil

JATAYU

Founded in 2012 under the SAEINDIA Collegiate Club of MAIT, Team Jatayu is a dynamic group of engineering students with a shared vision of redefining automotive engineering. Specializing in the design and development of All-Terrain Vehicles (ATVs), the team has consistently demonstrated a commitment to excellence, innovation, and technical mastery. Over the years, Team Jatayu has participated in numerous prestigious national and international competitions, including Baja SAE India, Baja SAE USA, and Enduro Student India. Their achievements not only highlight their engineering expertise but also reflect their resilience and ability to adapt to challenges. At its core, Team Jatayu thrives on collaboration and meticulous attention to detail. From conceptualizing advanced vehicle designs to executing complex manufacturing processes, the team has showcased an unparalleled ability to integrate academic knowledge with real-world applications. Their vehicles are known for their robust performance, innovative designs, and adherence to industry standards, making them a formidable competitor on any stage. Beyond competitions, Team Jatayu actively fosters a culture of learning and growth, mentoring juniors and contributing to the legacy of automotive excellence at MAIT. With a focus on pushing the boundaries of off-road vehicle engineering, Team Jatayu embodies the spirit of innovation and teamwork, paving the way for future generations of engineers to make their mark in the automotive industry.

Mr. R.C. Saini

Industrial Training at Daikin India Plant



The Department of Mechanical Engineering, MAIT, attended a 5-day industrial training at Daikin Airconditioning India Pvt. Ltd., Neemrana, from 6th to 10th January 2025. The program provided practical exposure to advanced manufacturing processes, HVAC technologies, and sustainable engineering. On Day 1, participants visited Daikin Factories 1 and 2, observing production lines for VRV systems, chillers, Sky Air units, and room ACs. They explored robotic assembly, quality control, and cutting-edge testing at India's largest Daikin R&D center. At DJIME, students learned about precision and skill in component assembly. The day also included an overview of Daikin's operations across India and a session on personal development and body language.



Webinar on Role of AI in Robots and Drones

MAHARAJA AGRASEN INSTITUTE OF TECHNOLOGY
DEPARTMENT OF MECHANICAL ENGINEERING

ORGANISING
WEBINAR ON

"ROLE OF AI IN ROBOTS AND DRONES"

February
01, 2025

11.00 AM Onwards

[Zoom Meeting Link](#)

Speaker:
DR. SHASHI SHEKHAR JHA
ASSISTANT PROFESSOR
IIT, ROPAR

For Registration:
<https://forms.gle/fojC1993LChIDG0d9E>

VISION of the Department
To be a global leader in Mechanical Engineering education, research & innovation with ethics and values.

MISSION of the Department
M1: To deliver industry relevant, skill oriented and research based education in Mechanical Engineering.



AR/VR with Drone Integration



The diagram illustrates the integration of AR/VR with drone technology. A Human Operator is shown at the bottom, connected to a drone above. A Head Position Indicator (HPI) is shown at the top, connected to the drone. The drone is shown in a 3D environment, and the HPI is shown with a red arrow pointing to the drone. The diagram is presented on a screen with a Windows taskbar at the bottom.

Artificial General Intelligence (AGI)

- AGI is the ability of an intelligent agent to understand or learn any intellectual task like a human being
- AGI can plan, learn cognitive abilities, make judgments, handle uncertain situations, and integrate prior knowledge in decision making or improve accuracy
- AGI facilitates machines to perform *innovative, imaginative, and creative* tasks
- AGI is also called strong AI, full AI, or general intelligent action



The slide features a list of bullet points defining AGI. To the right of the text is a small image of a robot head. Below the text is a large image of a human brain with a yellow highlight on a specific region, representing the concept of AGI. The slide is presented on a screen with a Windows taskbar at the bottom.

The Department of Mechanical Engineering, MAIT, Delhi, is organizing an insightful and forward-looking session on **"Role of AI in Robots and Drones"** scheduled for **1st February 2025 at 11:00 AM IST on Zoom**. This event aims to shed light on the rapidly growing integration of Artificial Intelligence in the fields of robotics and drone technology, revolutionizing automation, precision, and efficiency across industries.

The session will be conducted by **Dr. Shashi Shekhar Jha**, esteemed Assistant Professor at **IIT Ropar**, who brings extensive academic and research expertise in AI-driven systems. Participants will gain a deeper understanding of how AI algorithms enable autonomous decision-making, real-time navigation, obstacle avoidance, and intelligent data processing in robots and drones.

The session is open to **students, faculty, and professionals** who are eager to explore cutting-edge advancements and practical applications of AI in the modern engineering landscape. This is an excellent opportunity to enhance technical knowledge and stay updated with emerging trends in intelligent automation.

Bharat Mobility Global Expo 2025

Mechanical Engineering students from MAIT showcased their excellence at the Bharat Mobility Global Expo 2025, held at Bharat Mandapam, Delhi, from 17th to 22nd January. They actively managed floor areas at the Toyota, Greeves, and JBM halls, engaging with visitors by explaining vehicle specifications, features, and innovations. Their professionalism and technical knowledge significantly contributed to smooth event execution.



On 21st January 2025, dignitaries from MAIT, including Prof. J.V. Desai (Director General), Prof. Neelam Sharma (Director), Prof. Sachin Gupta (Dean – R&I), Prof. V.N. Mathur, Dr. Alok, Dr. Madhukar Chhimwal, and Mr. R.C. Saini, visited the expo to acknowledge and motivate the students. Their efforts received widespread appreciation, highlighting their ability to connect academic learning with practical industry experience.

Inter-College Cricket Tournament



The ASHRAE India Chapter proudly organized the 6th Inter-College Dr. Prem Jain Memorial Cricket Tournament on 25th January 2025, commemorating the extraordinary legacy of Dr. Prem Jain, widely regarded as the father of green buildings in India. This annual sporting event brought together students from several prestigious institutions, with a strong and enthusiastic participation from ASHRAE MAIT. The tournament not only celebrated the spirit of cricket but also served as a platform for promoting leadership, teamwork, healthy competition, and collaboration among future engineers. The matches were marked by outstanding sportsmanship, strategy, and dedication, reflecting unity and the core values championed by Dr. Prem Jain.

ASHRAE MAIT played a pivotal role in energizing the event, both through their on-field performance and off-field engagement. Their involvement emphasized the chapter's commitment to fostering holistic growth through a balance of technical and extracurricular pursuits. The tournament also provided students with opportunities to interact, network, and form lasting bonds across institutions. Congratulations to all the participating teams for their commendable efforts and true sportsmanship.

Innovation Project for the Indian Navy by Mr. Ankit Rai

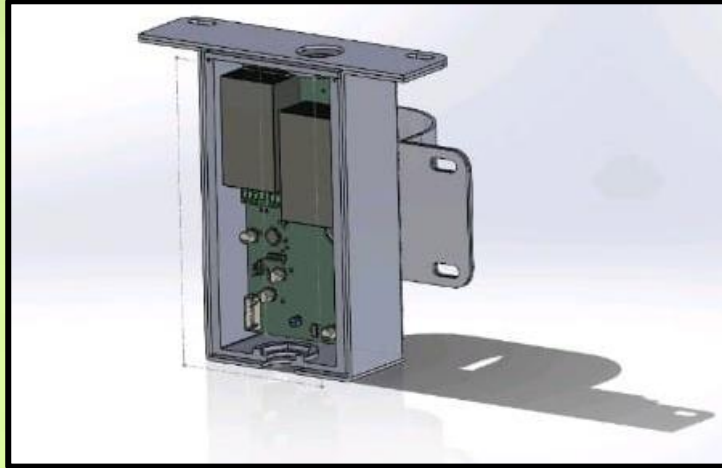

Mr. Ankit Rai, a 3rd-year student from the Department of Mechanical Engineering at MAIT, has brought immense pride to the institute with his outstanding contribution to the Indian Navy's Halo-Deck Upgradation Project. He successfully designed the Gyro Stabilized Horizontal Bar (GSHB) Lights, showcasing innovation, technical brilliance, and a deep understanding of real-world engineering applications.



MAHARAJA AGRASEN INSTITUTE OF TECHNOLOGY
DEPARTMENT OF MECHANICAL ENGINEERING

CONGRATULATES

Mr Ankit Rai for designing Gyro Stabilized Horizontal Bar (GSHB) Lights Under Halo-Deck Upgradation Project for The Indian Navy.

ANKIT RAI (ME)
02414811122

me.mait.ac.in For More Information **hodme.mait.ac.in**

His work not only supports national defense advancements but also serves as an inspiration for his peers and the entire MAIT Mechanical Engineering community.

Six-Month AICTE-QIP-PG Certificate Program

The Department of Mechanical Engineering at Maharaja Agrasen Institute of Technology takes immense pride in announcing the outstanding accomplishment of its distinguished faculty members—Dr. Vipin Kumar Sharma, Dr. Sidharth Bansal, Dr. Deshdeep Gambhir, Dr. Kanchan Mudgil, Dr. Sumit Joshi, and Ms. Surabhi Lata—who have successfully completed a prestigious Six-Month AICTE-QIP-PG Certificate Program, sponsored by AICTE and conducted in collaboration with premier institutions such as IITs and IIITs.

Through this rigorous programme, the faculty have gained advanced knowledge in some of the most transformative fields of modern engineering including Artificial Intelligence, Machine Learning, Data Science, Quantum Computing, and the Internet of Things (IoT). This achievement not only enhances their individual academic portfolios but also contributes to elevating the department's capability to offer forward-looking education rooted in innovation, interdisciplinary knowledge, and cutting-edge technology.

Their unwavering commitment to continuous learning and professional growth stands as an inspiration for students and peers alike, reaffirming MAIT's vision of excellence in technical education.



SBA Award for Dr. Vaibhav Jain at the ASHRAE Conference, Orlando, USA



Dr. Vaibhav Jain, Head of the Department of Mechanical Engineering at MAIT, has been honored with the prestigious 2024 SBA of the Year Award at the ASHRAE Winter Conference held in Orlando in February 2025. This esteemed recognition reflects his exceptional dedication, hard work, and significant contributions to the field of HVAC&R. Over the past four years, Dr. Jain has secured funding of approximately 1 lakh USD from ASHRAE, USA, supporting 14 projects and student scholarships. His achievement marks a proud moment for MAIT and reinforces the department's commitment to academic excellence and global engagement.



Blood Donation Camp by MATES



On Parakram Diwas 2025, Maharaja Agrasen Technical Education Society (MATES) organized a large-scale Blood Donation Camp at MAIT, New Delhi, to pay tribute to the legacy of Netaji Subhash Chandra Bose. The event was conducted in collaboration with the Rotary Club, Red Cross Society, RML Hospital, and Shree Aggarsain International Hospital, and was sponsored by the Rotary Club of Delhi Midwest and Union Bank of India. The initiative witnessed enthusiastic participation from students, faculty, and staff, collecting an impressive 520 units of blood. The event also included a free health checkup camp and began with a ceremonial tribute to Netaji. A special motivational session by Mr. Rahul Sholapurkar, a regular blood donor for over 47 years, inspired many first-time donors. Senior dignitaries of MATES and MAIT graced the event, appreciating the spirit of compassion, responsibility, and community service showcased by the youth.

The camp not only fostered awareness about the importance of blood donation but also reflected the institution's dedication to societal well-being. Each participant received refreshments and a certificate of appreciation. The overwhelming response reinforced the values of patriotism, service, and unity among the MAIT community.

Team Jatayu at eBAJA 2025, Hyderabad



Team Jatayu from the SAEINDIA Collegiate Club of MAIT showcased outstanding performance at the prestigious eBAJA 2025 event held at BVRIT, Narsapur, Hyderabad, from 20th to 26th February 2025. Demonstrating remarkable engineering prowess, the team successfully designed and fabricated a self-made electric All-Terrain Vehicle (eATV), earning recognition for their innovation, dedication, and teamwork. Guided by Mr. R. C. Saini, the 23-member team gained invaluable experience in leadership and technical excellence. Notably, five final-year students cleared the BAJA Aptitude Test (BAT), making them eligible for recruitment opportunities with top companies such as ARAI, Gravton, Varroc, Omen, and EKA.

In addition to the student achievements, the event also offered faculty members the chance to visit leading industrial hubs, including Mahindra Motors Zaheerabad, T-Hub Hyderabad, and Gravton Motors Hyderabad, enhancing their understanding of advanced industry practices. Team Jatayu's success is a proud reflection of MAIT's commitment to fostering innovation, practical learning, and industry-academia collaboration.

One-Week National Level FDP on "Green Manufacturing"

The One-Week National Level Faculty Development Program on "Green Manufacturing," held from 24th to 28th February 2025 at Maharaja Agrasen Institute of Technology (MAIT), New Delhi, in collaboration with NITTTR Chandigarh, concluded successfully. The program served as a dynamic platform for educators, researchers, and professionals to engage in discussions on sustainable manufacturing practices and cutting-edge green technologies. Featuring a blend of expert-led sessions, interactive discussions, and hands-on learning experiences, the FDP provided valuable insights into environmentally responsible engineering. The event witnessed enthusiastic participation and fostered a collective commitment toward a more sustainable future. The efforts of the organizers, speakers, and participants were instrumental in making this initiative impactful and knowledge-rich.



Industrial Training at Jindal SAW Ltd.

The Department of Mechanical Engineering organized a one-day industrial visit on 8th March 2025 for its esteemed faculty members to Jindal SAW Ltd., Kosi Kalan, U.P., offering a significant opportunity to bridge academic knowledge with real-world industrial practices. The visit provided hands-on exposure to various advanced manufacturing processes such as forming, submerged arc welding, annealing and quenching, and hydro testing each critical in the production of high-quality pipes used in vital sectors like oil, gas, and water transportation. Faculty members engaged with plant engineers and gained a better understanding of large-scale operations, material handling, and quality control techniques. The insightful interaction highlighted the relevance of engineering concepts in actual industry scenarios and will greatly enhance classroom delivery. Such initiatives not only foster industry-academia collaboration but also empower faculty to guide students with practical knowledge aligned to current industrial trends. The department extends heartfelt appreciation to Jindal SAW Ltd. for their warm hospitality, guided tour, and willingness to support educational growth.



Online Industrial Interaction with Jindal SAW Ltd.



The Department of Mechanical Engineering at MAIT organized an engaging online industrial interaction with Jindal SAW Ltd. on 11th March 2025, offering faculty members valuable insights into sustainable industrial practices. Led by Mr. Ankur Agnihotri, Deputy General Manager – Marketing & Contracts, the session focused on the company's commitment to achieving net-zero targets through innovative strategies. Key highlights included the implementation of circular practices to boost sustainability, reduction of greenhouse gas emissions, selection of suppliers with environmental certifications, and the use of advanced technologies to manage carbon footprints. This interaction fostered a deeper understanding of industry-driven sustainability efforts and enriched the academic perspective of the faculty. MAIT extends its gratitude to Jindal SAW Ltd. and Mr. Agnihotri for this informative and impactful session, further strengthening the bridge between academia and industry.

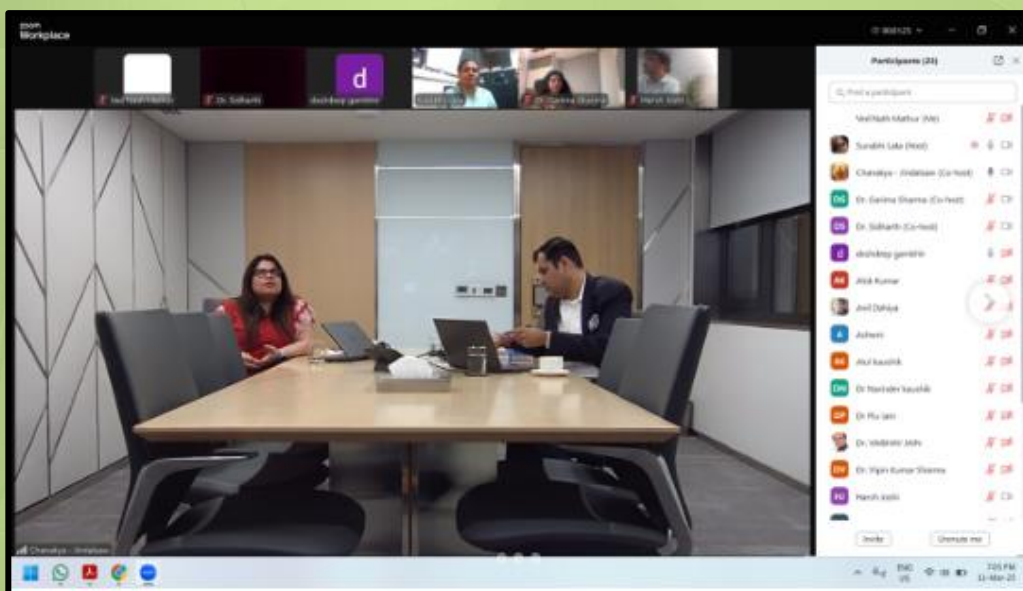

Industrial Visit to Yaskawa Pvt. Ltd



The Department of Mechanical Engineering at MAIT is proud to share the successful industrial visit of its students to Yaskawa India Pvt. Ltd., Gurugram—an industry leader in robotics and automation. During the visit, students gained first-hand exposure to cutting-edge robotic technologies, motion control systems, and real-time industrial automation applications.

Experts from Yaskawa provided insightful demonstrations and shared their knowledge on how robotics is transforming modern manufacturing. The visit significantly enriched students' practical understanding and helped bridge the gap between classroom learning and industrial practice.

The department extends heartfelt thanks to Yaskawa India Pvt. Ltd. for their valuable support and knowledge-sharing initiative.

Inaugural Event of ASME- MAIT Student Section

The Department of Mechanical Engineering at MAIT proudly inaugurated the ASME-MAIT Student Section on 10th March 2025. Themed “*Engineering Beyond Boundaries: ASME Awareness, Initiatives in India & Skills for Non-Core Jobs,*” the event marked a significant step in aligning students with global engineering standards and professional development pathways. Esteemed speakers Ms. Vaishnavi Soni and Ms. Jagruti Ajgaonkar delivered insightful sessions on automation, engineering codes, and skills essential for non-core roles. Under the guidance of Dr. Naveen Solanki, this initiative aims to foster industry-academia collaboration and prepare students for international opportunities. Key discussions included ASME’s global impact, emerging trends, and resources for career growth. With upcoming events like IMECE India 2025, the ASME-MAIT chapter sets the stage for an exciting journey ahead in innovation, networking, and skill development.



Seminar on Story of Mechanical Engineer After MS in the USA

On March 25, 2025, MAIT's Department of Mechanical Engineering had an extremely interesting session with distinguished Professor Sunil Garg. Prof. Garg talked about his incredible experience as a mechanical engineer during the event, emphasizing his experiences after earning an MS in the United States. His presentation gave students insightful information on new developments in the sector, international employment opportunities, and the transformational power of higher education. Attendees' interest and ambition were sparked by the lecture, which was both educational and inspiring. The department would like to express its sincere gratitude to Prof. Sunil Garg for sharing his time and expertise, as well as to all of the teachers and students whose enthusiastic involvement made the event a success.



Workshop Organized by Team Focus at Park Inn

At the Park Inn in Lajpat Nagar, on March 28, 2025, Team Focus hosted an enlightening workshop that brought together engineering students and industry professionals for a lively exchange of knowledge. The program included interesting presentations by Ms. Glory Shrivastava on "Future-Ready Indoor Spaces," which focused on intelligent technology integration and adaptable design, and Mr. K.L. Malhotra on "Acoustics in Indoor Environment Quality," which highlighted noise control techniques and acoustic comfort. Md. Kaunain (4th year), Gokul Chawla (3rd year), and Piyush & Rishabh (2nd year) enthusiastically represented the ASHRAE MAIT Chapter. They all actively participated and deepened their knowledge of new developments in the industry.

The department would like to express its sincere gratitude to the organizers and presenters for making the workshop an interesting and worthwhile educational experience.



One- Day Workshop on Multiphysics Simulation with Ansys



On April 1, 2025, the MAIT Mechanical Engineering Department successfully led a hands-on workshop on Ansys Multiphysics Simulation in partnership with CADFEM India and the ASME-MAIT Student Section. The session, titled "Mastering Multiphysics Simulation with Ansys: From Fundamentals to Advanced Applications," gave attendees a thorough introduction to the newest simulation technologies and included a live T-pipe model thermal analysis demonstration. The lesson improved students' comprehension of real-world simulation problems by providing the ideal balance of academic knowledge and real-world application. Special thanks go out to Dr. Naveen Solanki, ASME-MAIT Coordinator, for his significant assistance in making the event a success, and to Mr. Vignesh S. M., Application Engineer at CADFEM India, for his knowledgeable advice.



Workshop on Heat Load Estimation



The Department of Mechanical Engineering, MAIT organized a 7-days workshop on 'Heat Load Estimation', led by Mr. Vikram Bansal, Co-Chair, Student Activity, AIC, and his team.

The workshop covered key concepts in HVAC system design, starting with heat load calculations, including sensible and latent loads, internal and external gains, and ventilation effects. It progressed to the selection of suitable HVAC systems based on calculated requirements.

Hands-on sessions and case studies helped students apply theoretical knowledge to practical scenarios, offering insights into real-world industry practices. The workshop effectively bridged the gap between academics and industrial applications in refrigeration and air conditioning.

Industrial Visit to Shri Ram Pistons & Piston Rings Pvt. Ltd.

On April 16, 2025, the Mechanical Engineering students of MAIT had the enriching opportunity to visit Shri Ram Pistons & Piston Rings Ltd., Ghaziabad. One of India's premier automotive component manufacturers. The visit provided a comprehensive insight into the industrial production of pistons, piston rings, pins, and valves, featuring advanced robotics, precision machining, and cutting-edge R&D practices. Students explored over 20 production lines with a monthly output exceeding 15 lakh pistons and gained valuable knowledge on materials such as KS 1295, RIK 40, and SPR-02, used across a range of engines including gasoline, diesel, CNG, LNG, flex-fuel, and hydrogen. The visit also covered key processes like gravity die casting, ultrasonic testing, and molycoating, offering practical exposure that effectively bridged classroom concepts with real-world applications. The department extends sincere thanks to Shri Ram Pistons for their warm hospitality, and to faculty members Dr. Deshdeep Gambhir, Dr. Naveen Solanki, and Dr. Sumit Joshi for organizing this impactful industrial visit.



Job Expo & Capacity Building Session on JobX



Glimpses of Job Expo & Capacity Building Session



The Department of Mechanical Engineering at MAIT is proud to share the successful organization of the *Job Expo & Capacity Building Session on JobX* held on 21st April 2025, in collaboration with the National Skill Development Corporation (NSDC) and the Ministry of Skill Development & Entrepreneurship. This event marked the official launch of a week-long national promotional campaign for the NSDC JobX platform, running from 21st to 25th April 2025. The initiative aims to boost job seeker registrations, encourage active participation from trainees, alumni, and local youth, and mobilize communities through grassroots outreach. With lakhs of verified employment opportunities, JobX is fast becoming a transformative tool for skilled professionals across India. Participants were encouraged to promote awareness, complete profiles, and assist candidates in job applications to strengthen placement outcomes, enhance industry linkages, and increase their centers' credibility. The department extends its gratitude to all stakeholders for their enthusiastic participation and urges everyone to continue playing a vital role in empowering India's youth through meaningful employment opportunities.

Team Aerostars at Boeing National Aeromodelling Competition

On March 27, 2025, Team Aerostars from the Department of Mechanical Engineering, MAIT, proudly represented the institute at the prestigious Boeing National Aeromodelling Competition held at IIT Kanpur. Under the mentorship of Dr. Kanchan Mudgil and the guidance of Dr. Vaibhav Jain, HOD, ME Dept., the 18-member team took on two exhilarating challenges: the Fixed-Wing UAV Design Challenge and the Multirotor Competition. In the fixed-wing segment, the team showcased three custom-built aircraft integrating balsa wood, carbon fiber, foam board, and 3D-printed components to optimize payload efficiency, modularity, and agility. In the multirotor category, Team Aerostars stood out by successfully clearing the obstacle-laden Round 1 and emerging as the only team in Category B (shaft length 37.5–50 cm) to advance to Round 2. Their innovative QR-based payload recognition and precise flight control earned them 5th place nationally, along with a special mention for outstanding performance. The event also featured a defense technology expo, further igniting the team's enthusiasm for aerospace innovation.



Research Paper Presentation at ICACME 25 Conference

The Department of Mechanical Engineering at MAIT is proud to share that a research paper titled “**Simulation-Based Analysis of Nature-Inspired Voronoi Structures in Additive Manufacturing**” was successfully presented at the **International Conference on Advances and Creations in Mechanical Engineering 2025**, held from 2nd to 4th April 2025.

Authored by **Vasu Kumar, Mayank Agarwal, Surabhi Lata, U. Gayatri, and Tony Rhodes Kotchera**, the paper explores innovative design approaches in additive manufacturing using nature-inspired Voronoi structures. The conference was organized by **Sant Gajanan Maharaj College of Engineering, Mahagaon**, in association with the **Technology Research and Innovation Centre, Pune**.

This accomplishment showcases the department’s continued emphasis on cutting-edge research and its commitment to nurturing future-ready engineers through academic excellence and innovation.



ASME Seminar on AM & Chandigarh Section Launch

The Department of Mechanical Engineering at Maharaja Agrasen Institute of Technology (MAIT), Delhi, is proud to share the enthusiastic participation of its students in the prestigious ASME Engineering Education Seminar and Chandigarh Section Launch, held on April 8–9, 2025, at CSIR-CSIO, Chandigarh. Organized by ASME India in collaboration with CSIR-CSIO, the two-day event revolved around the theme “*Additive Manufacturing for Sustainability*” and featured expert talks and panel discussions on cutting-edge topics such as bio-printing, ceramic and concrete printing, and metal printing, highlighting their applications and challenges in fields like energy, healthcare, and space research. The MAIT student delegation actively engaged in the sessions, gaining valuable insights and networking with professionals from academia, industry, and research organizations. The department extends heartfelt thanks to the Head of the Mechanical Engineering Department and the dedicated faculty for their unwavering support in facilitating student participation in such a significant learning experience.



Industrial Visit to Haier India Pvt. Ltd.

The mechanical engineering students at MAIT, Delhi, had the chance to tour the Haier Industrial Park in Greater Noida on April 22, 2025.



This cutting-edge industrial complex is renowned for its inventive smart home solutions. Students gained important knowledge about contemporary industrial processes from the visit, especially how technologies are being incorporated into air conditioning and refrigeration systems. This first-hand experience demonstrated how smart connectivity is transforming climate control and appliance efficiency. Under the direction of faculty mentors Dr. Piu Jain and Dr. Surbhi Upadhyay, the tour was made even more enriching. Their academic support significantly improved the educational experience. Sincere gratitude is given by the department to Haier India for their kind hospitality and for motivating the upcoming generation of mechanical engineers.



Convocation Ceremony 2025

The Convocation Ceremony 2025 of Maharaja Agrasen Institute of Technology and Maharaja Agrasen Institute of Management Studies was held on 2nd May 2025 with great enthusiasm and pride. The event celebrated the academic achievements of graduating students in the presence of dignitaries, faculty, and families.

The ceremony was graced by Swami Balakanand Giri Ji Maharaj as the Chief Guest and Dr. Nand Kishore Garg as the Guest of Honour. Other key figures, including Prof. (Dr.) G.D. Verma and Prof. (Dr.) Sanjeev Kumar Sharma, addressed the gathering with words of encouragement and wisdom.

Students received their degrees with joy and gratitude, marking the culmination of their hard work and dedication. The event concluded with group photographs and heartfelt celebrations, making it a memorable milestone in the lives of the graduates.



Farewell Celebration 2021-25

On May 23, 2025, the Department of Mechanical Engineering at MAIT, Delhi, hosted a heartfelt farewell celebration for the outgoing Batch of 2021–2025. The event was a vibrant blend of joy, laughter, and nostalgia, featuring soulful performances and emotional reflections that captured the essence of the students' journey at MAIT. It was a fitting tribute to their dedication, achievements, and the lasting friendships they forged along the way. As they step into new chapters of their lives, the department extends its warmest wishes for continued success, happiness, and fulfillment in all their future endeavors.



Visit of The Fourth Valley Concierge Corporation Team

On 26th May 2025, the Fourth Valley Concierge Corporation team from Japan visited the Mechanical Engineering Department at MAIT. During their visit, they explored various laboratories, including the Automobile Engineering Lab, Workshop Lab, Machine Shop, CAD Lab, and the Refrigeration & Air Conditioning Lab. The team actively interacted with students, sharing insights about Japan's work culture and the career opportunities available for engineers in Japan. The session concluded with an engaging Q&A segment, where students participated enthusiastically, making the visit both informative and interactive.



Academic-Industry Collaboration Visit to Mitutoyo India Pvt. Ltd.



As part of ongoing efforts to strengthen industry-academia collaboration, Mr. R.C. Saini and Dr. Anil Kumar Dahiya visited Mitutoyo India Pvt. Ltd. on 24 June 2025. Mitutoyo is a global leader in precision measuring instruments and metrology solutions.

The visit offered valuable exposure to advanced measurement technologies and quality assurance systems employed in modern manufacturing environments. Through direct interactions with industry professionals, the delegation gained meaningful insights into real-world applications and emerging trends in precision engineering.

This engagement is expected to play a significant role in aligning academic curricula with industry practices, thereby enhancing students' readiness for future careers in engineering and manufacturing sectors.



Awareness Drive on Sustainable Refrigeration by ASHRAE

On the occasion of World Refrigeration Day, 26th June 2025, the students of ASHRAE MAIT organized an awareness drive focused on promoting sustainable and cost-effective refrigeration solutions. As part of this community outreach initiative, earthen pots were distributed among underprivileged communities to showcase natural, eco-friendly alternatives for cooling. The effort aimed to raise awareness about sustainable refrigeration practices that are both practical and impactful at the grassroots level. Special thanks to the ASHRAE India Chapter for their continued support and for providing the earthen pots that made this initiative possible. Through such efforts, ASHRAE MAIT remains committed to driving real-world change.



Industrial Training at Daikin India Pvt. Ltd, Neemrana

35 students from the **Mechanical Engineering Department of MAIT** successfully completed a **two-week residential training** at the **Daikin R&D Plant, Neemrana**. The program provided hands-on experience with advanced HVAC technologies and valuable industry exposure.

As part of the training, students presented their projects, applying the concepts learned in real time. The group of **Mayank Agarwal, Parv Yadav, Rishank Dabas, and Vansh Choudhary** was awarded the **Best Presentation**, while **Sanskar, Prisha Sagar, and Vasu Kumar** earned the **Second Best Presentation**. Their projects stood out for their technical depth, clarity, and innovative approach.

The experience helped students strengthen their practical skills and teamwork abilities.

It was a proud moment for the department, reflecting our focus on experiential learning.



Industrial Visit to Relaxo Footwear by Academic Team



On 9th July 2025, faculty members from Maharaja Agrasen Institute – Dr. Surbhi Upadhyay, Dr. Anil Kumar Dahiya, Dr. Piu Jain, and Dr. Garima Sharma – visited Relaxo Footwear Company as part of the institute's ongoing industry-academia collaboration.

The visit offered valuable insights into the company's innovative design processes, efficient manufacturing systems, and sustainability practices. Through direct interaction with on-ground teams, the faculty gained a deeper understanding of current industry trends, operations, and expectations.

This engagement not only enhanced academic-industry alignment but also reinforced the institute's commitment to practical, performance-driven learning. It was a meaningful step toward bridging the gap between classroom knowledge and real-world application.

Dr. Vaibhav Jain Appointed as BOG Member and Chair – Student Activities, ASHRAE India Chapter

Dr. Vaibhav Jain, Head of the Department of Mechanical Engineering, has been appointed as a **Board of Governors (BOG) Member and Chair – Student Activities** for the **ASHRAE India Chapter** for the academic year **2025–26**. The appointment was made during the AGM Installation Ceremony and marks a proud moment for the department and institution. This recognition reflects his consistent dedication to academic excellence, innovation in HVAC&R education, and his impactful efforts to promote student engagement and leadership.

His commitment to mentorship, research, and industry collaboration has contributed significantly to the professional development of engineering students. As he takes on this national-level responsibility, he is expected to play a key role in shaping student-focused initiatives and driving meaningful contributions within ASHRAE. His leadership is poised to bring new energy and direction to student activities across the chapter. His journey remains an inspiration to the academic and engineering community.



CSR Grant by EMS Ltd. for development of Off Road Vehicle

Maharaja Agrasen Institute of Technology (MAIT) has successfully signed a Grant Agreement with EMS Limited as part of their Corporate Social Responsibility (CSR) initiative. Under this collaboration, EMS Limited has extended a generous grant of ₹3, 00,000 to support enthusiastic engineering students engaged in the design, fabrication, and development of an innovative off-road vehicle.

This project aims to foster hands-on learning and technical excellence among students by supporting key aspects such as material procurement, assembly, testing, logistics, and participation in national-level events. The support from EMS will play a vital role in turning student ideas into impactful real-world engineering solutions.

EMS Limited has offered their valuable contribution towards encouraging student innovation and promoting a strong industry-academia partnership at MAIT.

 **MAHARAJA AGRASEN INSTITUTE OF TECHNOLOGY**
(ISO 9001:2015 Certified)
 APPROVED BY AICTE, MINISTRY OF HRD, GOVT OF INDIA
 (AFFILIATED TO GURU GOBIND SINGH INDRAPRASTHA UNIVERSITY, DELHI)

Ref. No. ME/SAE/2025/12 Date 23/06/2025

"GRANT AGREEMENT"

- Grant - CSR Expenditure ("Grant")**
 - EMS LIMITED is a company registered under the with Companies Act, 2013, having its Registered office at C-88, Raj Nagar Dist Centre, Raj Nagar, Ghaziabad, Uttar Pradesh, India, Pin - 201002.
 - Maharaja Agrasen Technical Education Society ("Grantee") is a Society Registered under the Societies Registration Act-XXI of 1860 having its registered office at House No. 10, Road -4, Keshav Kunj, East Punjabi Bagh New Delhi-110019.
 - The Grantee has provided a proposal to EMS limited ("Proposal") for supporting group of forty students pursuing bachelor degree under different engineering streams and engaged in project aimed at attaining engineering breakthrough in design and manufacturing of off-road vehicle. EMS has agreed to contribute Rs. 2,00,000/- towards Grant towards the Project, in the manner and subject to the terms and conditions of this agreement ("Grant Agreement").
 - The Grant will be used by the Grantee only for the purposes of implementing the Project-related activities, including but not limited to design, engineering, fabrication, assembly, testing, and validation of the vehicle; procurement of materials and components; registration and compliance with event regulations; logistics and shipping of equipment and vehicle; team travel and accommodation; participation in workshops and technical inspections; and any other operational or administrative tasks necessary for manufacturing the vehicle and attending the events.
- Payment of Grant**
EMS Limited intends to contribute the Grant in one tranche as mutually agreed with the Grantee.
- Reports and Records**
 - The Grantee shall provide to EMS Limited progress reports from time to time, each of which must include a narrative portion and a financial portion and prepared in accordance with Indian generally accepted accounting procedures and must detail Grantee's use of Grant funds and must be signed by an authorized officer of Grantee.
 - The Grantee must maintain all accounting records, for the use of Grant funds. Further, all such records and reports must be made available to EMS limited for examination upon request at any time.
- Representations of the Grantee**

- 1 -

MAHARAJA AGRASEN CHOWK, SECTOR-22, ROHINI, DELHI- 110086
 PHONES - 8448186931/35 TELEFAX:011-27582095 E-mail: ma@maitech.ac.in

The Grantee represents and warrants as follows:

- The Grantee is registered under section 12AA and 80G of the Income-tax Act, 1961
- It has its principal place of business located at its address set forth on page one of this Grant Letter;
- It has all requisite corporate or other power, and has all material governmental licenses, authorizations, consents and approvals necessary to own its assets and undertake the activities as are now being or as are proposed to be conducted by the Grantee; and
- There are no legal or arbitral proceedings, or any proceedings by or before any governmental or regulatory authority or agency, now pending or (to its knowledge) threatened against it, if adversely determined, could affect its ability to perform the activities contemplated by this Grant Agreement or the validity or enforceability of this Grant Agreement, or the rights and remedies hereunder.

5. Non-Assignment
This Grant shall not be assigned or transferred to any third party, or to any affiliate, successor, or assign of Grantee without the prior consent of EMS Limited.

6. Entire Understanding
This Grant Agreement constitute the entire understanding between the parties in relation to the subject matter of this Grant Agreement.

Please indicate your acceptance to the foregoing by signing.

For and on behalf of EMS Limited.

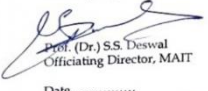
 By RAVI PR SINGH
 Title CHAIRMAN
 Date 26/6/25

AGREED:

 Prof. (Dr.) S. S. Deswal
 Officiating Director, MAIT
 Date

Prof. Dr. S. S. Deswal
 Dean MAIT
 Maharaja Agrasen Institute of Technology
 Maharaja Agrasen Chowk, Sector-22,
 Rohini, Delhi-110086

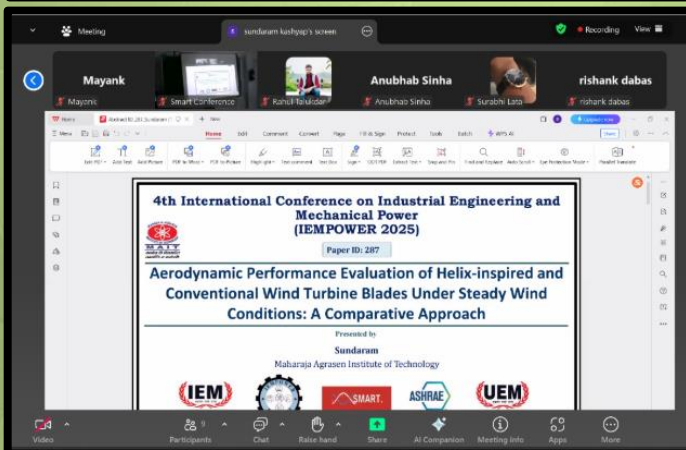
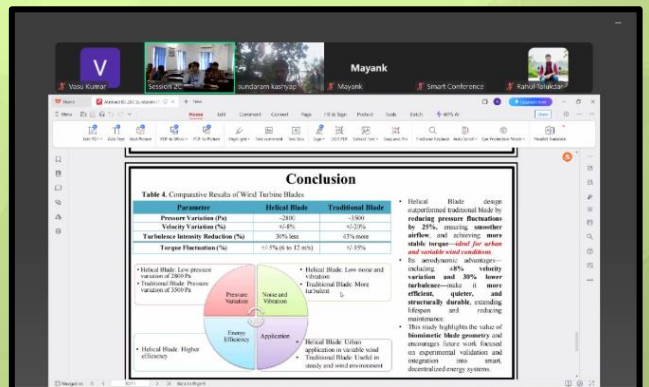
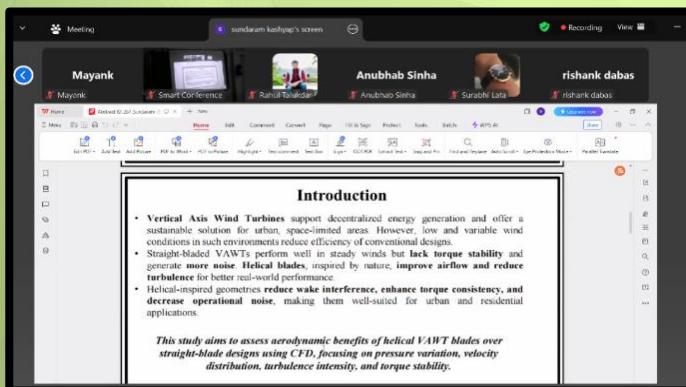
Research Paper Presentation at 4th International Conference on Industrial Engineering and Mechanical Power 2025

Sundaram, a student of Maharaja Agrasen Institute of Technology, successfully presented a research paper which was co-authored by **Mayank Agarwal, Rishank Dabas, Vasu Kumar, Piyush and Vansh Choudhary** at the **4th International Conference on Industrial Engineering and Mechanical Power 2025** on 18th-20th July 2025. The paper, titled **“Aerodynamic Performance Evaluation of Helix-inspired and Conventional Wind Turbine Blades Under Steady Wind Conditions: A Comparative Approach”**, explores a detailed performance analysis of wind turbine blades under steady wind conditions, offering insights into optimizing wind energy systems for higher efficiency and sustainability. This conference, supported by reputed organizations including **IEM, ASHRAE, SMART, and UEM**, provided an excellent platform to showcase.



Industrial Visit to Relaxo Industries by Faculty Team

A faculty team from Maharaja Agrasen Institute of Technology visited Relaxo Industries on 25th July 2025 as part of an academic-industry collaboration initiative. The visit provided valuable insights into modern manufacturing technologies, including automation, lean production systems, and quality assurance practices implemented by one of India's leading footwear brands. Faculty members Dr. Surbhi Upadhyay, Dr. Anil Kumar Dahiya, Dr. Piu Jain, and Dr. Garima Sharma participated in the visit, gaining first-hand exposure to industrial workflows and operational excellence. This interaction served as a meaningful bridge between theoretical learning and real-world application, reinforcing the importance of industry-integrated education.



Three Days Staff Training Program

Department of Mechanical Engineering at Maharaja Agrasen Institute of Technology (MAIT) successfully conducted a Three-Day Staff Training Program on “*Artificial Intelligence in Creating Arts*” from 23rd to 25th July 2025.

The program aimed to introduce staff members to the creative use of AI in visual and digital arts. Sessions covered Microsoft tools for poster and brochure design, design fundamentals like layout, image editing, and typography, as well as training on Canva for graphic creation using AI-powered features.

The final session focused on advanced AI tools such as ChatGPT, DALL·E, and DeepArt, enabling participants to explore AI-generated visuals through hands-on activities. The program encouraged innovative thinking and highlighted the role of emerging technologies in enhancing creative teaching



 **MAHARAJA AGRASEN INSTITUTE OF TECHNOLOGY**
(AFFILIATED TO GGSIP UNIVERSITY, DELHI)
MAHARAJA AGRASEN CHOWK, SECTOR-22, ROHINI, DELHI-110086 

DEPARTMENT OF MECHANICAL ENGINEERING

Organizing
a
Three days
STAFF TRAINING PROGRAMME
23rd-25th July, 2025
on
AI IN CREATING ARTS
TIME : 11.00-12.00 AM
ROOM NO : 212
RESOURCE PERSON: **MS. SURABHI LATA**

VISION:
To be a global leader in Mechanical Engineering education, research & innovation with ethics and values.

MISSION:
To deliver industry-relevant and skill-oriented education in Mechanical Engineering, fostering ethical values, professional skills, and innovation across Production, Design, Thermal, and Emerging Areas. Through modern pedagogical tools, research, and entrepreneurship, we aim to promote sustainable technologies, continuous learning, and collaborative engagement with alumni, industry, and stakeholders for societal and industrial growth.

me.mait.ac.in For Further Information hodme@mait.ac.in

Recognition with Rising Star Award in ASHRAE Challenge

Mayank Jatety and Gokul Chawla, final-year students of Department of Mechanical Engineering, MAIT have received the prestigious Rising Star recognition in the 2025 Setty Family Foundation Applied Engineering Challenge, organized by ASHRAE. This esteemed achievement reflects their exceptional innovation, technical expertise, and commitment to sustainable engineering solutions.

As part of this recognition, they have been invited to attend the 2026 ASHRAE Winter Conference in Las Vegas, USA, with complete sponsorship of travel and accommodation—a remarkable opportunity to represent our institute on an international platform. This accomplishment stands as a testament to the talent and determination of our students and marks a proud moment for the entire MAIT community. Heartiest congratulations to Mayank and Gokul on this stellar success. We wish them continued growth and excellence in all their future endeavors.



Congratulations!

RISING STAR RECOGNITION

ASHRAE 2025 Applied Engineering Challenge



Mayank Jatety



Gokul Chawla

We are proud to announce that **Mayank Jatety** and **Gokul Chawla** from our student Branch **Maharaja Agrasen Institute of Technology** have received the **Rising Star Recognition** in the prestigious **2025 Setty Family Foundation Applied Engineering Challenge** organized by **ASHRAE, USA**.



Achievement includes:

Invitation to attend the **2026 ASHRAE Winter Conference** in Las Vegas, USA, with sponsored travel and accommodation.

Interaction of MEGA group with Team Aerostar and SAE Club



Department of Mechanical Engineering, Maharaja Agrasen Institute of Technology, hosted a distinguished delegation from **MEGA Group, Japan** on **31st July 2025**. This international interaction was held with members of **Team Aerostar** and the **SAE Collegiate Club**, as part of the ongoing efforts to promote global exposure and academic-industry collaboration.

During the visit, Team Aerostar presented their innovative **drone technology projects**, reflecting the creativity, technical expertise, and forward-thinking mindset of our student innovators. The delegation also toured the **SAE Society**, where they witnessed impressive student-built vehicles and cutting-edge concepts in **automobile design and engineering**.

The MEGA Group engaged in meaningful discussions with students, highlighting the **vast job opportunities available in Japan** for Mechanical Engineering graduates. The exchange of ideas, cultural perspectives, and industry insights made the event highly enriching for all participants. This interaction not only broadened the horizons of our budding engineers but also laid the foundation for future international collaborations.

PhD. Award for Dr. Surbhi Upadhyay

Ms. Surbhi Upadhyay has successfully completed her Doctor of Philosophy (Ph.D.) from Delhi Technological University (DTU) in the Department of Mechanical Engineering. Her thesis, titled “*Study of Planning and Control Aspects in Manufacturing*” was evaluated and approved following her Viva-Voce examination held on 6th June 2025. This remarkable academic milestone was guided under the esteemed supervision of Prof. Suresh Kumar Garg and Dr. Rishu Sharma.

No. DTU/Results/Ph. D./2025/799



Delhi Technological University
(Formerly Delhi College of Engineering)
Shahbad Daultpur, Bawana Road, Delhi – 110 042, India

Consequent upon the evaluation of the thesis submitted by the candidate(s) as per details given below for the award of Doctor of Philosophy (Ph.D.) of the Delhi Technological University on the topic as mentioned against his/her name and after his/her viva-voce examinations, he/she/they has/have been found qualified for the Award of Degree of Doctor of Philosophy (Ph.D.).

Department of Mechanical Engineering

S.No.	Roll No.	Name of Student	Name of Student (In Hindi)	Discipline	Date of Viva - Voce Examination	Name of Supervisor/Co-Supervisor(s)
1.	2K18/PHDME/38	Surbhi Upadhyay	सुरभि उपध्याय	Mechanical Engineering	6th June, 2025	Prof. Suresh Kumar Garg & Dr. Rishu Sharma
Title of Ph.D Thesis		Title in English: Study of planning and control aspects in manufacturing		Title in Hindi: स्टडी ऑफ प्लानिंग एंड कंट्रोल एस्पेक्ट्स इन मैनुफैक्चरिंग		

 In-charge (Results)
 Dated: 16.06.2025

 Controller of Examination





Maharaja Agrasen Institute of Technology

Department of Mechanical Engineering

Brahmgupt Block, Block No. II,
Maharaja Agrasen Institute of Technology
PSP Area, Plot No. 1, Sector – 22, Rohini, Delhi – 110086.